

On the Gravitational Time Delay Effect and the Curvature of Space

Volodymyr Krasnoholovets

Indra Scientific SA
Square du Solbosch 26, Brussels B-1050, Belgium
E-mail: v_kras@yahoo.com

Abstract

Starting from a sub microscopic point of view the gravitational time delay effect (the Shapiro effect) is described in detail. Two different microscopic approaches to the study of the photon delay caused by a gravitating body are examined: the variational procedure of classical mathematics and the fractal changes of the fundamental tessellattice of space. It is shown that only the second approach brings about a reasonable alteration to the photon path consistent with the experimental result. Namely, the gravitating body contracts cells of space and hence photons hopping from cell to cell run through a larger number of cells, which results in a lengthening of the whole photon path.

Keywords: time delay, curvature, tessellattice, fractality

1. Introduction

The Shapiro [1,2] time delay effect, or gravitational time delay effect, is one of the four available classic solar system tests of general relativity. Shapiro sent radar signals from the Earth to the Mars, which passed near the Sun and took a little bit longer time to travel to the target and back, than it should occur in the case when the Sun was not present. The signal path is longer than the straight-line path between the planets due to deflection by the gravitational field of the Sun. The measured time delay 200 μ s was also calculated [1,2] on the basis of the Schwarzschild metric of the Sun. General relativity introduces nonlinearity to the flat metric, such that the time component $g_{44} = 1$ gains the appropriate correction $g_{44} = 1 - 2GM/(c^2 r)$ (see, e.g. Ref. 3). Later the time delay effect was observed for the binary pulsar PSR 1913+16 [4] and the phenomenon is applied to various other cases.

There are a few other alternative approaches, which agree with experimental data, to the resolution of the three classical tests: the motion of the Mercury's, the light deflection of starlight by the Sun and the gravitational redshift of light. In particular, the motion of Mercury perihelion was considered by Giné [5], Dubois [6], Anderton [7] and the author [8]; the light deflection of starlight by the Sun was treated by Giné [9] and the author [8]; the gravitational redshift of spectral lines also was described by the author [8]. Berger [9] developed his own alternative approach to the description of all four classical tests of general relativity: the perihelion precession of Mercury, the deflection of light by the Sun, the redshift of light and the Shapiro time delay effect.

Berger's calculations were based on the laws of classical physics with assumptions that the velocity of a test object near the gravitational centre is $v = c\sqrt{1 + 4GM/(rc^2)}$ and the gravitational constant G is not a constant but a function with a similar dependence $G' = G \cdot (1 + 4GM/(rc^2))$. Bergers' study of the Shapiro time delay effect raises a question whether the photon path becomes longer due to an alteration of physical parameters or the longer path is associated with a real geometric change of space.

Suntola [11] developed his very original approach to the description of the universe, the so-called dynamic universe. In his theory locally observed phenomena are derived from the conservation of the zero-energy balance of motion and gravitation in whole universe. Inertial work looks as the reduction of the rest energy due to motion in space, which gives a quantitative explanation to March's principle. By using this approach, Suntola derives correct expressions for the perihelion precession of Mercury, the deflection of light by the Sun, the redshift of light and the Shapiro time delay effect; besides he describes also the Sagnac effect. In his theory the velocity of light is locally variable and can drop at the gravitational interaction.

In the present paper the Shapiro time delay effect is treated from the viewpoint of submicroscopic concept.

2. Submicroscopic Concept

A sub microscopic approach, which is applied below, also gives a detailed explanation of the phenomenon. In the author's works [12,8,13] a theory of gravitation appears as a continuation of the developed submicroscopic (subquantum) mechanics of elementary particles and the theory of ordinary physical space that has been constituted as a tessellation lattice of primary topological balls [14-17]; this mathematical lattice has been called a tessell-lattice.

A physical particle is treated as a local deformation of this mathematical tessell-lattice, i.e. a volumetric fractal deformation of a cell of the tessell-lattice. The motion of the particle through such structure is necessarily associated with the interaction of the particle with surrounding cells of the tessell-lattice. The motion can be described by a Lagrangian [18-22]

$$L = -m_0c^2 \left\{ 1 - 1/(m_0c^2) \left[m_0\dot{x}^2 + \mu_0\dot{\chi}^2 - 2\pi/T \sqrt{m_0\mu_0} (x\dot{\chi} - v_0\chi) \right] \right\}^{1/2} \quad (1)$$

where m_0 is the particle's mass, x is its position; μ_0 is the mass of excited cloud of excitations of the tessell-lattice (they were named *inertons*, because they are associated with the field of inertia of the particle), χ is the position of the centre mass of the cloud; $1/T$ is the frequency of collisions of the particle with the cloud of inertons; v_0 is the initial velocity of the particle and c is the speed of light. This Lagrangian is constructed as an inner development of the so-called relativistic Lagrangian of a particle

$$L = -m_0c^2 \sqrt{1 - v_0^2/c^2}.$$

The moving particle is rubbing against the tessell-lattice, which results in the appearance of the particle's cloud of inertons. But this is not a classic friction that stops the particle.

Indeed, the Euler-Lagrange equations: $d/dt(\partial L/\partial \dot{q}) - \partial L/\partial q = 0$

for the particle ($q \equiv x$) and its inerton cloud ($q \equiv \chi$), which are based on the Lagrangian 1, result in periodical solutions:

$$\dot{x} = v_0 \cdot (1 - |\sin(\pi t/T)|), \quad (2)$$

$$x = v_0 t + \lambda/\pi \cdot \{(-1)^{[t/T]} \cos(\pi t/T) - (1 + 2[t/T])\}, \quad (3)$$

$$\dot{\chi} = \Lambda/\pi \cdot |\sin(\pi t/T)|, \quad (4)$$

$$\dot{\chi} = (-1)^{[t/T]} c \cos(\pi t/T), \quad (5)$$

$$\lambda = v_0 T, \quad \Lambda = cT. \quad (6)$$

Expressions 2 and 3 show that the particle's velocity periodically oscillates and λ is the amplitude of particle's oscillations along its path. In particular, λ is the period of oscillation of the particle's velocity that periodically changes between v_0 and zero. The inertons cloud periodically leaves the particle and then comes back; Λ is the amplitude of oscillations of the cloud and c is the velocity of the cloud of inertons. The Lagrangian 1 allows us to introduce an effective Hamiltonian of the particle, which describes its behaviour relative to the centre of inertia of the particle-inerton cloud system

$$H_{\text{eff}} = p^2/(2m) + m[2\pi/(2T)]^2 X^2/2 \quad (7)$$

where $m = m_0/\sqrt{1 - v_0^2/c^2}$. This is the harmonic oscillator Hamiltonian, which means that we can construct the Hamilton-Jacobi equation for a shortened action S_1 of the particle

$$(\partial S_1/\partial x)^2/(2m) + m[2\pi/(2T)]^2 X^2/2 = E \quad (8)$$

where E is the energy of the moving particle. Introduction of the action-angle variables leads to the following increment of the particle action within the cyclic period $2T$,

$$\Delta S_1 = \oint p dx = E \cdot 2T \quad (9)$$

Eq. 9 can be rewritten by using the frequency $\nu = 1/(2T)$. At the same time $1/T$ is the frequency of collisions of the particle with its inertons cloud. Allowance for $E = mv_0^2/2$ gets

$$\Delta S_1 = mv_0 \cdot v_0 T = p_0 \lambda \quad (10)$$

where $p_0 = mv_0$ is the particle's initial momentum. If we equate the value ΔS_1 to Planck's constant h , we obtain instead of expressions 9 and 10 the major de Broglie's relationships

$$E = h\nu, \quad \lambda = h/p, \quad (11)$$

which form the basis of conventional quantum mechanics.

Relationships 11 allow one to derive the Schrödinger equation

$$-\frac{\hbar^2}{2m}\nabla^2\psi(r,t)+V(r)\psi(r,t)=E\psi(r,t). \quad (12)$$

The submicroscopic concept developed in the real space on the scale of Planck's length operates with a particle and the particle's cloud of inertons. Conventional quantum mechanics, which was evolved in an abstract phase space on an atom scale, works with the wave ψ -function. These two approaches can be combined if we assume that the inerton cloud of an entity, which is associated with the entity's field of inertia, represents a substructure of the entity's "mysterious" ψ -wave function.

Therefore, the cloud's inertons are a substructure of the matter waves and they are field carriers that transfer mass and fractal properties from the particle to distant points of space.

A range of space covered by the particle's ψ -wave function is specified by the amplitude of the inerton cloud, $\Lambda = \lambda c / v_0$ (which is spread in transversal directions of the particle's path), and the particle's de Broglie wavelength λ along the particle's path (c is the speed of light that is the velocity of migrating inertons in the inerton cloud, which are transversal to the particle's path; v_0 is the initial velocity of the particle, and also the component of the velocity of the inerton cloud along the particle's path). If the particle is motionless, its inertia and gravitation are restricted in the particle's deformation coat whose radius coincides with the particle's Compton wavelength $\lambda_{\text{Com}} = h/(mc)$ where m is the particle's mass.

In a macroscopic object local oscillations of entities generate inerton clouds, which overlap, forming a set of harmonics of inerton waves in the object [23]. Moreover, long-wave inerton harmonics go far beyond the physical size of the object. These oscillating waves bear mass properties to a great distance away from the object. Oscillating waves mean that inertons emitted by the object return to it, which signifies that these inerton waves are standing spherical waves.

Solutions to standing spherical waves are characterised by the inverse dependence on the distance to the wave's front. Standing inerton waves of a macroscopic object were studied in works [12,8,13] where it has been shown that at the average, the standing inerton wave results in a quasi-stationary mass potential field around the object with a mass M_0 , which is subjected to spherical symmetry

$$M \sim M_0 / r. \quad (13)$$

This average mass field automatically results in the Newton's gravitational potential

$$U = -GM / r. \quad (14)$$

Besides, the notion of a point mass, which is typical for general relativity, cannot be a real point but rather a small macroscopic object whose smallest radius can be estimated at around 1 μm .

In paper [8] the submicroscopic theory has been further developed for the interaction of mass objects; it was exhibited that the gravitational interaction between two mass objects should be described by a corrected Newton's law

$$U = -G \frac{MM_1}{r} \cdot \left(1 + \frac{\dot{r}_{\text{tan}}^2}{c^2} \right), \quad (15)$$

where \dot{r}_{tan} is the tangential velocity of a test mass M_1 , which is in line with Poincaré's remark [24] that an expression for the gravitational interaction should include the velocity of a moving object. By using expression 15, the submicroscopic approach has been applied to describe three macroscopic phenomena: the motion of Mercury's perihelion, bending of a light ray by a star and the red shift of spectral lines. The approach allowed us to derive exactly the same equations for the description of the three phenomena as those that were predicted by general relativity (see, e.g. Ref. 3). This means that the solutions are also identical.

An important feature of the sub microscopic theory [12,8,13] is the derivation of Newton's gravitational law, expression 14. The study shows that the metric of a mass object is flat, because the mass object does not possess any singularity in its gravitational field. Nonlinearity has manifested itself only at the interaction with a test object. A package of photons, which travels near the mass object, does not disturb the space, because photons do not form inerton clouds around themselves and hence cannot participate in the reciprocal interaction through inerton clouds with the mass object. Therefore, the first term in expression 3 does not affect photons. Only the second term of expression 3 is responsible for the deflection of photons of a gravitating body, which results in the deflection of a light ray by the angle [8]

$$\varphi = 4GM / (c^2 r) \quad (16)$$

(this result in the agreement with that obtained in the framework of the phenomenological formalism of general relativity, see, e.g. Ref. 25). Here r is the radius of a gravitating body; in the case of the sun it is the Sun's radius.

In this note we apply the submicroscopic theory of gravitation [12,8,13] to the description of Shapiro's time delay effect.

3. A photon Path in the Vicinity of a Gravitating Body

Let us consider a path of photons that travel from one planet to the other and come back passing near the Sun (Figure 1). A conventional consideration is based on a variational technique. Time has to be treated as a natural parameter,

$$t = \int \frac{ds}{c}, \quad (17)$$

where ds is the interval length of the path of photons and c is the constant, the velocity of light. A ray of light, which comes by a gravitating body with the mass M and the radius R , has to be deflected in compliance with expression 16.

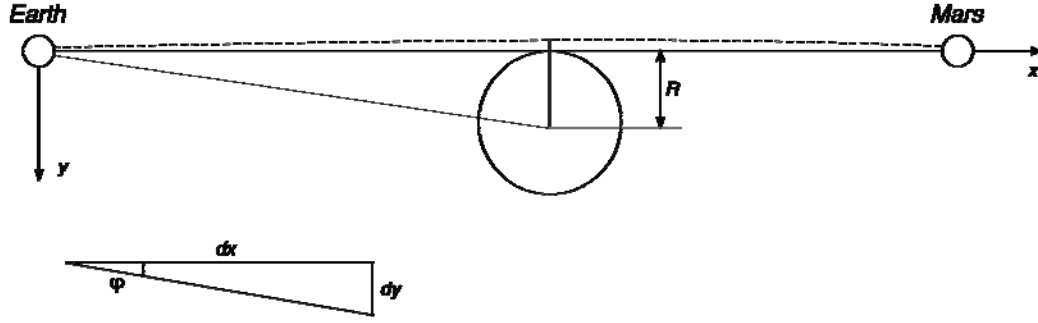

Figure 1. Photon path from one planet to the other, which passes near the Sun. The x-axes line is a straight line; the upper line (dotted line) is the real path of photons. Below in the text we use the following designations: the distance from Earth to the Sun is r_1 , the distance from the Sun to Mars is r_2 and the distance from Earth to Mars is $r_1 + r_2$.

3.1. Classical Mathematical Variational Procedure

Following classical mathematics, namely, the variational procedure, we can write

$$t = \int \frac{ds}{c} = \int \frac{\sqrt{dx^2 + dy^2}}{c} = \int \frac{\sqrt{1 + [\varphi'(x)]^2}}{c} dx \quad (18)$$

where the function $y(x)$ is defined in expression 16 and Figure 1:

$$y(x) \equiv \varphi(x) = \frac{4GM}{c^2 \sqrt{R^2 + x^2}} \quad (19)$$

and, therefore, its derivative becomes

$$\varphi'(x) = -\frac{4GMx}{c^2 (R^2 + x^2)^{3/2}}. \quad (20)$$

Such approach does not require any uncertainties at extremely low distances, which are prescribed by the formalism of quantum mechanics, because at the sub microscopic consideration nature is indeed deterministic even at its minimal scale [13].

Substituting form 20 into expression 18 we obtain

$$\begin{aligned} t &= \frac{R}{c} \int d\chi \sqrt{1 + \left(\frac{4GM}{c^2 R}\right)^2 \frac{1}{(1 + \chi^2)^3}} \cong \frac{R}{c} \int d\chi + \frac{R}{2c} \int \left(\frac{4GM}{c^2 R}\right)^2 \frac{d\chi}{(1 + \chi^2)^3} \\ &= \frac{R}{c} \left(2 \int_{\text{Earth}}^{\text{Sun}} d\chi + 2 \int_{\text{Mars}}^{\text{Sun}} d\chi \right) + \frac{R}{2c} \left(\frac{4GM}{c^2 R}\right)^2 \left(2 \int_{\text{Earth}}^{\text{Sun}} \frac{d\chi}{(1 + \chi^2)^3} + 2 \int_{\text{Mars}}^{\text{Sun}} \frac{d\chi}{(1 + \chi^2)^3} \right) \end{aligned} \quad (21)$$

where $\chi = x/R$ is the dimensionless variable.

From expression 21 we get for the time delay

$$\delta t \approx \frac{R}{2c} \left(\frac{4GM}{c^2 R} \right)^2 2 \left(\frac{\chi}{\sqrt{1+\chi^2}} \Big|_{\chi=0}^{\chi=r_1/R} + \frac{\chi}{\sqrt{1+\chi^2}} \Big|_{\chi=0}^{\chi=(r_1+r_2)/R} \right) \quad (22)$$

where r_1 and r_2 are distances from the Earth to the Sun and from Mars to the Sun, respectively.

Physical constants are: $G = 6.673 \times 10^{-11} \text{ m}^3 \text{ kg}^{-1} \text{ s}^{-2}$, $M = 1.99 \times 10^{30} \text{ kg}$, $r_1 = 149.6 \times 10^9 \text{ m}$, $r_2 = 227.94 \times 10^9 \text{ m}$, $R = 0.695 \times 10^9 \text{ m}$ and $c = 3 \times 10^8 \text{ m/s}$. Substituting these constants into expression 10 we get an estimation of the time delay

$$\delta t \sim 10^{-11} \text{ s}, \quad (23)$$

which is 5 orders less than the experimental result and the value obtained by Shapiro [1,2] on the basis of Schwarzschild metric's components.

3.2. Fractal Changes in the Photon Path

A submicroscopic consideration allows us to determine deeper the proper time of migrating photons in the different way. Photons, as mass quasi-particles [13], have to interact with the mass body via the second term of expression 15. This interaction with the body's total interton cloud changes the path of photons near the body, expression 4, which one can perceive as a local space curvature. Since the real space is organised as the tessell-lattice of topological balls [14-17], the space curvature can easily be illustrated by changes in geometry of cells of the tessell-lattice around the mass object. Then in this case the proper time of photons, form 17, becomes

$$t = \int \frac{ds}{c} = \int \frac{dx}{c} + \int \varphi \frac{dx}{c} \quad (24)$$

and thus the time delay, i.e. the second term in the right hand side of expression 24, appears as follows

$$\Delta t = \int \varphi(x) \frac{dx}{c} \quad (25)$$

where the angle of deflection $\varphi(x)$ is defined in expression 19. Calculating the integral in 25 we obtain

$$\begin{aligned} \Delta t &= \frac{4GM}{c^3} \left(2 \int_0^{r_1/R} \frac{d\chi}{\sqrt{1+\chi^2}} + 2 \int_{r_1/R}^{(r_1+r_2)/R} \frac{d\chi}{\sqrt{1+\chi^2}} \right) \\ &= \frac{4GM}{c^3} 2 \left[\ln(\chi + \sqrt{1+\chi^2}) \Big|_0^{r_1/R} + \ln(\chi + \sqrt{1+\chi^2}) \Big|_{r_1/R}^{(r_1+r_2)/R} \right] \\ &= \frac{4GM}{c^3} 2 \ln \left(2 \frac{r_1+r_2}{R} \right) \approx 2 \times 10^{-4} \text{ s}. \end{aligned} \quad (26)$$

Note the numerical value of the result 26 **coincides exactly** with Shapiro's outcome [1].

In the tessel-lattice, which represents an inner structure of real physical space, volumetric fractal changes of cells are associated with the physical notion of mass. But what is the gravitating body's inerton cloud doing around the body? It distributes a mass potential around the body, which results in the induction of Newton's gravitational law 14 and 15. In its turn the induction of mass in the space means the appearance of volumetric fractal changes in appropriate cells of the tessel-lattice.

This means that the tessel-lattice really shrinks around the body, as is schematically shown in Figure 2. Then for the problem displayed in Figure 1, the photon path acquires additional cells in comparison with the case of a degenerate space (when a gravitating mass is absent). Note such investigation is in agreement with general rules of fractal geometry (see, e.g. Ref. 26), which in reality makes it possible to measure a curve by means of the number of balls that cover it.

Studies of Bounias and the author [14-17] allowed us to introduce an additional rule towards a ball, namely, its feasible fractal volumetric changes.

Now putting the size of a topological ball of degenerate space (a cell of the undisturbed tessel-lattice) equal to the Planck's size $\ell_p = \sqrt{\hbar G / c^3} \cong 1.616 \times 10^{-35}$ m, we may estimate the number of cells that introduce the time delay, expression 26. The number of cells, which form a path for photons that hop from cell to cell with the constant velocity c , is

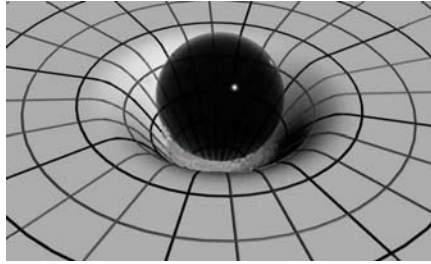

Figure 2. Curvature of space as a fractal volumetric spherical deformation of cells of the tessel-lattice caused by standing inerton spherical waves of the gravitating body.

$$N = \frac{1}{\ell_p} \int_0^{r_1+r_2} dx = \frac{r_1+r_2}{\ell_p} \sim 10^{46}. \quad (27)$$

An additional number of cells involved in the path due to the cells' fractal volumetric shrinking caused by the mass M and the interaction of photon with the gravitational field of this mass via the second term in expression 15, is

$$\Delta N = \frac{1}{\ell_p} \int_0^{r_1+r_2} \varphi(x) dx = \frac{4GM}{c^2 \ell_p} 2 \ln \left(2 \frac{r_1+r_2}{R} \right) \sim 10^{39}. \quad (28)$$

Thus, the Sun's gravitational field shrinks the tessell-lattice, such that the number N of cells in a rectilinear path between the Earth and the Mars increases by the value of ΔN , which is the maximum in the case when the path lays in the immediate vicinity of the Sun (in this case $\Delta N \sim 10^{39}$, expression 28).

4. Conclusion

General relativity showed that Newton's law of gravitation was not adequate to account for certain gravitational experiments, namely: the motion of Mercury perihelion, the bending of a light ray, the gravitational red shift of spectroscopic lines and the Shapiro time delay effect. General relativity, as an abstract formal theory, used Newton's law as the major term, but could not suggest any reasonable physical substitution for Newton's law of gravitation.

In contrast to orthodox quantum theory and general relativity, the submicroscopic concept allows us to derive the Newton gravitational potential [12], expression 14, and to introduce the corrected version of Newton's law of gravitation [8], expression 15, for interacting objects, which allows a description and submicroscopic interpretation of four macroscopic phenomena mentioned above. Owing to the inerton field introduced by the submicroscopic concept, which has already been tested in many experiments from a microscopic to cosmic scale, hypotheses resting on general relativity, such as gravitational waves and black holes have to be complete reviewed and possibly abandoned.

A curvature of space originates from a metric in particular Schwarzschild's that represents properties of the geometry of space-time of a point mass M at rest. Nevertheless, as shown in paper [8] the geometric metric includes implicitly the second term of physical interaction, expression 15, of the mass M with a small test mass m in the location of the latter. The present paper further develops the submicroscopic concept showing that it is fractality of the tessell-lattice, which is exhibited in the vicinity of a gravitating body accounting for the appearance of the so-called non-flat space-time metric of general relativity.

That is why fractality of the tessell-lattice and fractality of balls, which compose the tessell-lattice, are responsible for the real geometry of physical space. This means that space-time of general relativity is disclosed as the four dimensional space of the tessell-lattice. In the tessell-lattice the fundamental metrics of the ordinary physical space are represented by a convolution product where the embedding part allows the description by the following relation [15]

$$D4 = \int \left(\int_{dV} (d\vec{x} \cdot d\vec{y} \cdot d\vec{z}) \right) * d\Psi(w) \quad (29)$$

where dV is an element of space, and $d\Psi(w)$ a function accounting for the extension of coordinates to the 4th dimension through convolution (*) with the volume of space. The fourth dimension reflects the space fractality, i.e. fractality of the tessell-lattice's balls. Time determined as a natural parameter through the path, expression 17, can

change only in the case when balls, which form the path, shrink. Therefore non-linear components of metric of general relativity shall be considered as a mapping of original shrunk balls of the tessel-lattice.

References

- [1] I. I. Shapiro (1964). Fourth test of general relativity, *Phys. Rev. Lett.* 13, No. 26, 789-791.
- [2] I. I. Shapiro, G. H. Pettengill, M. E. Ash, M. L. Stone, W. B. Smith, R. P. Ingalls, and R. A. Brockelman (1968). Fourth test of general relativity: Preliminary results, *Phys. Rev. Lett.* 20, No. 22, 1265-1269.
- [3] P. G. Bergmann (1942). *Introduction to the theory of relativity*. Prentice-Hall, Inc., Englewood Cliffs, New Jersey, p. 203 (Russian translation: Gos. Izd. Inostrannoy Literatury, Moscow, 1947, p. 271).
- [4] J. H. Taylor, J. M. Weinsberg (1989). Further experimental tests of relativistic gravity using the binary pulsar PSR 1913+16, *Astrophys. J.* 345, 434-450.
- [5] J. Giné (2008). On the origin of the anomalous precession of Mercury's perihelion, *Chaos, Solitons and Fractals* 38, 1004–1010.
- [6] D. M. Dubois (2008). Incursive algorithms for Newtonian and relativistic gravitations, and simulation of the Mercury orbit, *Int. J. Computing Anticipatory Systems* 20, 3-16.
- [7] R. J. Anderton (2009). Nahhas' Newtonian derivation of Planet Mercury advance of perihelion of 43" seconds of an arc century, *The General Science Journal*, <http://www.k1man.com/f2.pdf>.
- [8] V. Krasnoholovets (2009). On microscopic interpretation of phenomena predicted by the formalism of general relativity, in *Ether Space-Time and Cosmology, Vol. 2. New Insights into a Key Physical Medium*. Eds.: M. C. Duffy, J. Levy (Apeiron, 2009), pp. 417-431. (Publisher: C. Roy Keys Inc., Apeiron, ISBN: 0973291184; 978-0973291186). Also: *Apeiron* 16, No. 3, 418-438 (2009); <http://redshift.vif.com/JournalFiles/V16NO3PDF/V16N3KRA.pdf>.
- [9] J. Giné (2008). On the origin of the deflection of light, *Chaos, Solitons and Fractals* 35, 1–6.
- [10] G. Berger (2008). An alternative theory of gravitation, derived from the Fatio-Le Sage theory, *Apeiron* 15, No. 3, 235-253.
- [11] T. Suntola (2009). The dynamic universe, in: *Ether, Spacetime and Cosmology, Vol. 2. New Insights into a Key Physical Medium*, Eds.: M. Duffy and J. Levy. Apeiron, Montreal, pp. 67-134.
- [12] V. Krasnoholovets (2008). Reasons for the gravitational mass and the problem of quantum gravity, in: *Ether Spacetime and Cosmology. Vol. 1. Modern Ether Concepts Relativity and Geometry*, Eds.: M. Duffy, J. Levy and V. Krasnoholovets. PD Publications, Liverpool, pp. 419-450 (ISBN 1 873 694 10 5); also [arXiv.org: 1104.5270](http://arXiv.org:1104.5270) (physics.gen-ph).
- [13] V. Krasnoholovets (2010). Inerton fields: Very new ideas on fundamental physics, Eds.: R. L. Amoroso, P. Rowlands and S. Jeffers. *American Inst. Phys. Conf. Proc.*

- December 22, 2010 - Volume 1316, pp. 244-268. Search for fundamental theory: The VII International Symposium Honoring French Mathematical Physicist Jean-Pierre Vigi er; doi: 10.1063/1.3536437.
- [14] M. Bounias and V. Krasnoholovets (2003). Scanning the structure of ill-known spaces: Part 1. Founding principles about mathematical constitution of space, *The Kybernetes: The Int. J. Systems and Cybernetics* 32, No. 7/8, 945-975; also arXiv.org: physics/0211096.
- [15] M. Bounias and V. Krasnoholovets (2003). Scanning the structure of ill-known spaces: Part 2. Principles of construction of physical space, *ibid.* 32, No. 7/8, 976-1004. arXiv: physics/0212004.
- [16] M. Bounias and V. Krasnoholovets (2003). Scanning the structure of ill-known spaces: Part 3. Distribution of topological structures at elementary and cosmic scales, *ibid.* 32, No. 7/8, 1005-1020; also arXiv: physics/0301049.
- [17] M. Bounias and V. Krasnoholovets (2004). The universe from nothing: A mathematical lattice of empty sets. *Int. J. Anticipatory Computing Systems* 16, 3-24, Ed.: D. Dubois; also arXiv: physics/0309102.
- [18] V. Krasnoholovets and D. Ivanovsky (1993). Motion of a particle and the vacuum. *Physics Essays* 6, No. 4, 554-563; also arXiv: quant-ph/9910023.
- [19] V. Krasnoholovets (1997). Motion of a relativistic particle and the vacuum. *Physics Essays* 10, No. 3, 407-416; also arXiv: quant-ph/9903077.
- [20] V. Krasnoholovets (2000). On the nature of spin, inertia and gravity of a moving canonical particle. *Indian J. Theor. Phys.* 48, No. 2, 97-132; also arXiv: quant-ph/0103110.
- [21] V. Krasnoholovets (2000). Space structure and quantum mechanics. *Spacetime & Substance* 1, No. 4, 172-175; also arXiv: quant-ph/0106106.
- [22] V. Krasnoholovets (2002). Submicroscopic deterministic quantum mechanics. *Int. J. Computing Anticipatory Systems* 11, pp. 164-179; also arXiv: quant-ph/0109012.
- [23] V. Krasnoholovets (2010). On variation in mass of entities in condensed media, *App. Phys. Research* 2, No. 1, 46-59, ISSN: 1916-9639; E-ISSN: 1916-9647; <http://ccsenet.org/journal/index.php/apr/article/view/4287>.
- [24] H. Poincar e (1906). Sur la dynamique de l' electron, *Rendiconti del Circolo matematico di Palermo* 21, 129-176; also: *Oeuvres*, t. IX, pp. 494-550 (also in (Russian translation: H. Poincar e, *Selected Transactions*, ed. N. N. Bogolubov Nauka, Moscow, 1974, Vol. 3, pp. 429-486).
- [25] See Ref. 3: Ch. 14, p. 292 (Russian translation).
- [26] J. Feder, *Fractals* (1988). Premium Press, New York and London, Ch. 2.